

Building Permits

The purpose of a building permit and the building codes are to provide minimum construction standards to safeguard life and property. The City also reviews permit applications for zoning matters to ensure that the City continues to be a safe, beautiful area in which to live, work and play. The City's building and zoning codes have been carefully enacted to protect the health, safety and general welfare of you and your property.

A building permit is required for any work that physically changes or adds structures to your property. There are many exemptions from building permits. Please review form B-39 for information on these exemptions or contact building staff at 760-

602-2719. Even though a permit may not be needed for certain accessory structures, setbacks and other zoning regulations still apply. Contact the Planning Division at 760-602-4610 for this information.

You, as homeowner, preparing a do-it-yourself project (an owner-builder), or your general contractor, architect or designer may apply for the permit. The homeowner must still sign the "owner-builder disclaimer" on the application before the permit is issued. Your permit can also be issued to your contractor with proof of a current state contractor license, workers' compensation policy and City of Carlsbad business license.

Hours

The Community Development offices are open between 7:30 a.m. and 5:30 p.m. Monday –Thursday and 8:00 a.m. and 5:00 p.m. Fridays.

Grading Permits

You may need a grading permit if your project meets any of the criteria below:

- Cut or proposed fill exceeding 100 cubic yards per 8,000 square feet of area.
- Excavations exceeding four (4) feet or fill exceeding three (3) feet.
- Fill placed on existing slopes exceeding 5:1 horizontal to vertical slope
- Grading that affects drainage patterns.
- If the toe of a slope is closer than three (3) feet to a property line.
- If your project meets any of the above criteria, contact the Engineering Division for assistance at 760-602-2750.

Plan Review

The period allowed per the Building Code for the entire Plan Check process is 1 year from date of submission. The initial Plan Review normally takes between 12 to 14 working days. Comments and corrections are mailed directly back to the contact person listed on the application. Re-review of corrected plans, if necessary, takes 7 to 10 working days. The contact person will be notified when the permit is ready to be issued. At issuance, a building permit, a copy of the approved of plans and a Yellow Job Record Card will be given to the state licensed contractor or property owner. Both the approved plans and the yellow Job Record Card (which is signed by the City inspector as each phase of construction passes inspection) must be present on the job site.

Submittal Requirements

Please call or email your request for submittal appointment: 760-602-2723 or devappt@carlsbadca.gov.

Plans

To process an application for a single family dwelling, a residential remodel, or a room addition you will need:

- Completed Building Permit Application, with attached forms, available at the building counter or at <http://www.carlsbadca.gov/building>
- 3 Sets of plans
- 2 copies of a soils report (if required)
- 2 copies of Energy calculations or other documentation

Soils reports are required for additions to two story homes, the addition of a second story to an

existing single story and for any addition over 500 square feet. Additions under 500 square feet may require a soils report at a later date, if, when inspecting the footings/foundation excavation, the City Building Inspector finds conditions which warrant an additional review by a soils engineer.

If the project is in the Coastal Zone, you will need approval of the project or an exemption letter from the California Coastal Commission prior to permit issuance. The Planning Division can tell you whether your project is in the Coastal Zone and can be contacted at 760-602-4601.

Title Sheet

The title sheet of the plans must show the following information:

- Site address
- Assessor's Parcel Number
- Legal Description, lot #, Map #, CT#
- Amount of grading in cubic yards. Write "No Grading" on the plot plan if none is required.
- Contact and owner information including name and daytime phone.
- Scope of Work
- Vicinity Map

Plot Plan

All plans must have a plot plan. The plot plan must show

- Site address and name of Owner.
- The entire parcel with the footprint of the proposed structure or addition and any existing structures on the entire property. The footprint should show all bay windows, fireplaces, overhangs and projections and eave overhangs. The plot plan must be dimensioned and drawn to scale, usually 1" equals 10 feet.
- Zoning
- Lot width and setbacks, indicated and dimensioned
- Street/alley centerline (if applicable)
- Existing and proposed slopes and/or retaining walls.
- Percentage of lot coverage. (Total area of all structures on lot as proposed, divided by total lot area)
- Locations, names and widths of bordering streets, road easements and alleys
- Locations of easements.
- Existing and proposed public right-of-way and improvements within the public right-of-way (Irrevocable Offer to Dedicate – if applicable)
- Drainage pattern on site.

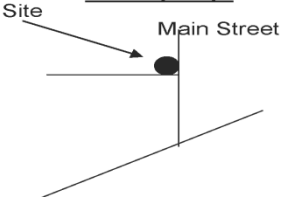
<p><u>Owner:</u> Carl Sample 123 Sample Street Sample Town, US 90000 Ph. 700-700-7000</p> <p><u>Contact:</u> Mike Sample 124 Sample Street Sample Town, US 90000 Ph. 700-700-8000</p> <p><u>Site Address:</u> 123 Sample Street Sample Town, US 90000 APN# 500-500-50 2.8 acres (net)</p> <p><u>Summary Table</u> <u>Existing:</u> SFD, 2,500 sq.ft. Attached Garage, 800 sq.ft.</p> <p><u>Proposed:</u> Recreation room, 1,200 sq.ft. Pool 850 sq.ft.</p> <p>↑ North Scale 1" = 20'</p> <p><u>Vicinity Map:</u></p> 
--

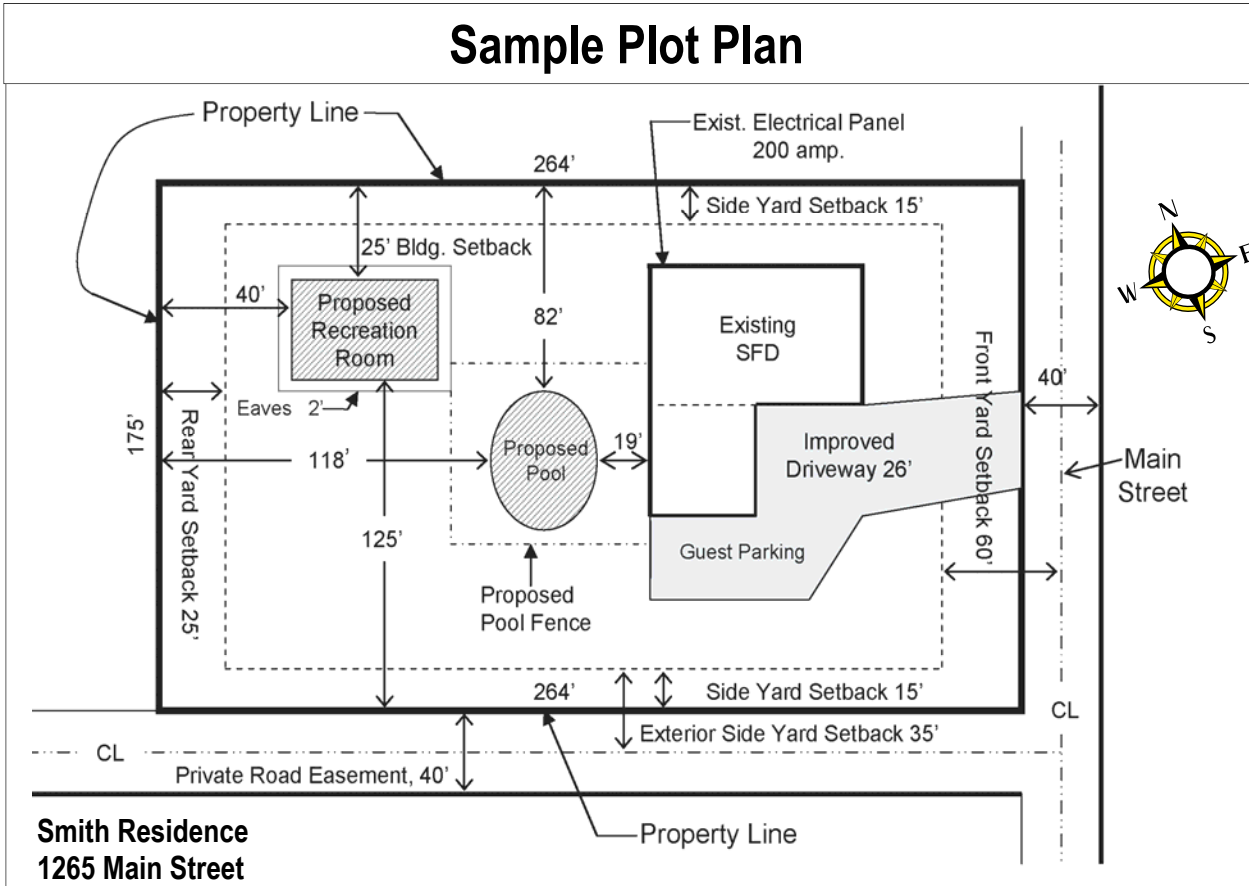

Floor Plans, Building Sections and Elevations

Plans must show a **Floor plan** of the proposed addition. This is an overhead view of the rooms labeled with the use of the rooms (bedrooms, kitchen, bathroom, etc). The floor plan, or attached details, should show the size of any area by the construction, the location, size and type of all window, doors and other openings; location of plumbing fixtures, light fixtures and electrical outlets; location type(s) of heating and air conditioning units; sill height of bedroom windows, and the type of all interior finishes. For room additions, all adjacent rooms to the addition(s) shall also be shown.

Elevations are exterior views of the proposed structure from each side. Elevations show all openings and exits, vertical dimension, location and type of wall bracing, the type of roof covering and exterior finishes. Include and indicate the following items:

- Existing and finished grade (labeled on each view).
- Maximum height. Structure height is to be measure from the lower of existing or finished grade. Clearly show both grades and note if same on all elevation; dimension maximum height of structure.
- Additions: Clearly indicate what is existing and what is proposed.

For two story structures and for structures with complex roof framing systems, a **Cross-section** view of the proposed building is required. A section drawing is an internal view of the framing system of the structure generally taken at the mid-point of the structure. This includes spacing of the joists, girders, and rafter. Show the clearance from earth to wood floor, ceiling heights, eaves projections and roof pitch. These are also drawn at 1/4 inch equals 1 foot scale.

Sample Floor Plan

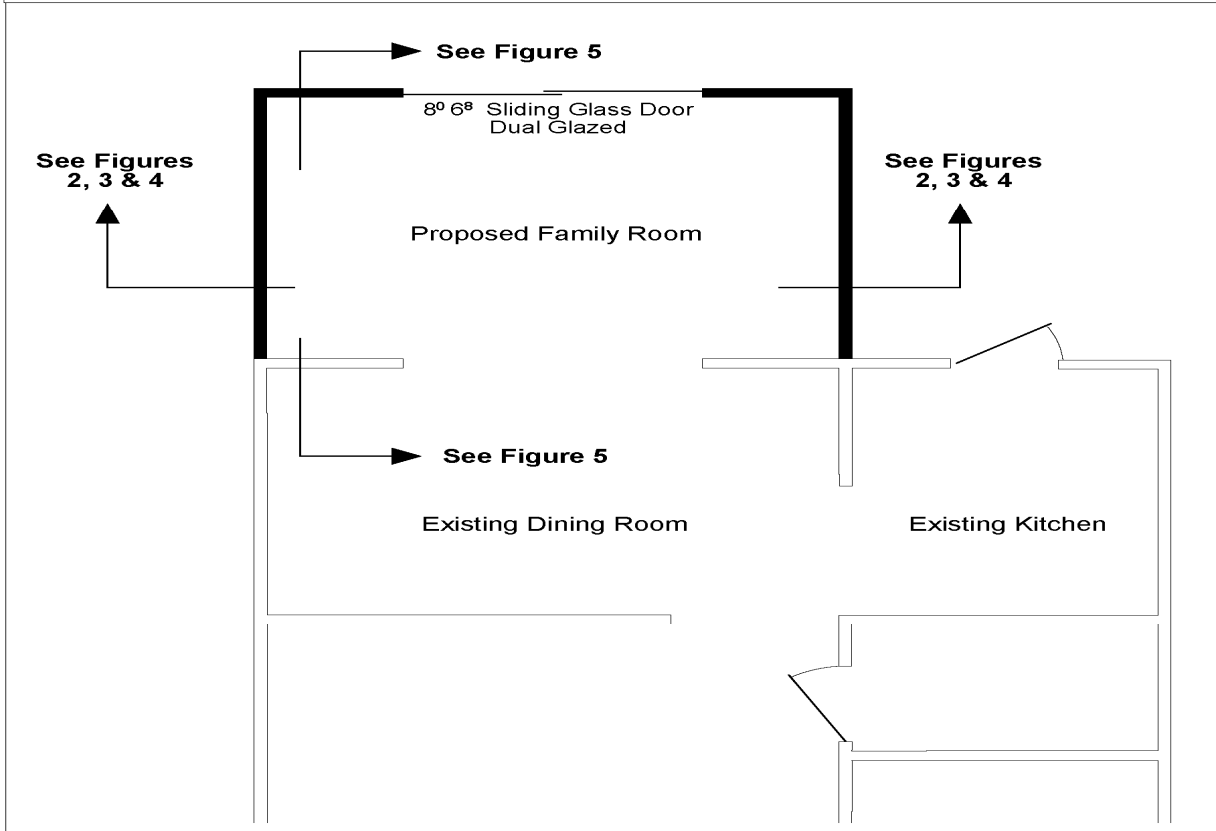

Sample Section Details

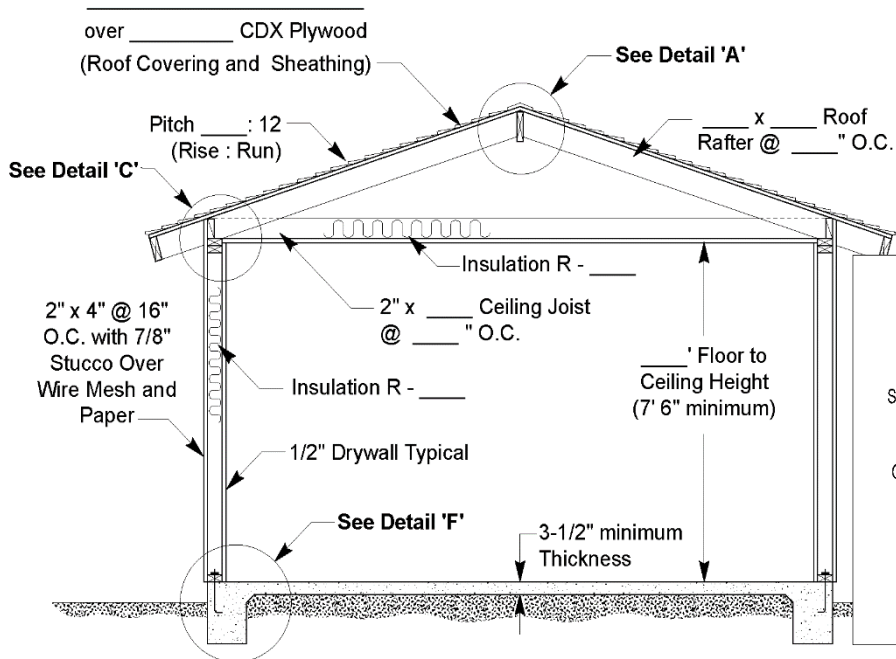

Sufficient details must be shown to clearly explain the method of construction and means of connection.

Detail 'F'

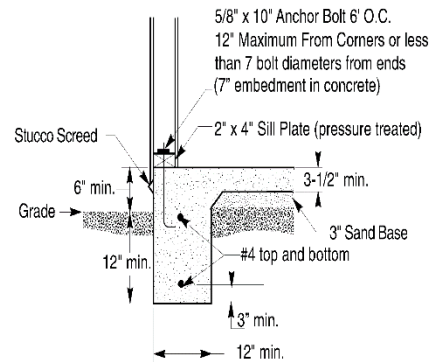

Sample Elevation Plan



Foundation Plan and Framing Plans

Foundation plans show the size and location of footings, walls and piers, size and spacing of girders and floor joists; thickness of concrete slabs, and depth of fills, if any, and special treatment of the soil, if any is required.

Framing plans are plan views of floor and roof framing systems showing all lumber sizes and spacing, and any hardware connectors indicated for each system. Additional details in larger scale may be necessary for complex connections.

Title 24 Energy Documentation

All single-family or duplex additions or alterations are required to comply with California Energy Efficiency Standards for Low-Rise Residential Buildings contained in the California Code of Regulations, Title 24, Part 1. A number of compliance methods are described in a Residential Manual available from the California Energy Commission, phone 1-800-772-3300.

Minimum acceptable requirements for the simplest method of meeting the requirements are shown in Table 1. You may complete the required Certificate of Compliance: CF-1R form using the information shown in Table 1. You must also show the required insulation values and dual pane windows on your plans. Also complete a Mandatory Measures Checklist (MF-1R) form by checking all the items that apply to your project.

The CF-1R form and the Mandatory Measures Checklist MF-1R form are available at the Development Services Center.

Table 1 – Title Energy Requirements
(Climate Zone 7)

Floor Area	<101 sq. ft.	<1000 sq. ft.
Insulation:		
Ceiling	R-19	R-30
Wall	R-13	R-13
Floor	R-13	R-19
Glass		
Type	Dual Pane	Dual Pane
Sq. Ft.	Max. 50*	20% of FA*

*The area of any glass removed, as a direct result of the room addition, may be added to the 20%.

Inspections

You will receive a yellow Job Record Card, referred to as the "Inspection Card". The inspector signs the card as the construction is inspected and approved. The minimum inspections generally required are:

- Underground Plumbing (if necessary)
- Foundation and Footings
- Roof and Exterior Sheathing (this allows the building to be weather protected while construction continues)
- Combination: Framing, Rough Plumbing, Rough Mechanical and Rough electrical
- Insulation
- Drywall and Exterior Lathing
- Final Inspection

To schedule an inspection, call 760-602-2725. This is a voicemail system that records your request. If you call before 3:00 p.m. Monday through Friday the inspection will be made the next working day. Field inspectors are usually available between 7:30-8:00 a.m. to answer questions or schedule approximate inspection times. The inspectors will try to accommodate your schedule whenever possible depending on their daily workload. To speak to an inspector, call 760-602-2700 between 7:30-8:00 a.m. weekdays. Building inspectors endeavor to schedule appointments within 2-hour windows.

The Inspection Record, the approved plans, and the permit are important records and should be preserved.